



FEATURES

- Small, compact contactor for switching 1000+Vdc
- UL508 Recognized and load break rated for 1000vdc systems
- Designed to meet UL1604 for hazardous locations, class I and II, Div2 and class III
- Patented EPIC® Hermetic Seal – Exceeds IP67-69 specifications – No exposed arcing to open air environments
- Perfect for solar, photovoltaic, inverter systems, battery packs, combiner boxes, DC arc fault interrupter systems or any other high voltage DC system
- High Efficiency Dual DC Coils – Very low 12, 24, or 48Vdc continuous power coils with no EMI emissions or cross-talk on your system control power – Ideal for battery powered systems or where low coil power consumption is needed
- Stand up mounting with integrated safety cover – Finger safe, touch safe protection
- Designed and Manufactured in Carpinteria, CA USA

PRODUCT SPECIFICATIONS

Specifications	Units	Data
Contact Arrangement		
Main	Form X	SPST-NO
Auxiliary (2A, 24VDC) ⁹	Form A or B	SPST-NO or SPST-NC
Mechanical Life	cycles	1,000,000
Contact Resistance¹		
Max	mohms	0.4
Typical	mohms	0.15 to 0.3
Operate Time²		
Max	ms	20
Typical	ms	13
Release Time, Max	ms	12
Insulation Resistance³	Mohms	100
Dielectric At Sea Level (Leakage < 1mA)	VRMS	4,300
Shock, 1/2 Sine, 11ms	G peak	20
Vibration, Sinusoidal (500-2000 Hz Peak)	G	15
Ambient Temp Range		
Operating ⁴	°C	-55 to +85
Storage	°C	-70 to +150
Weight, Typical	Kg (Lb)	0.44 (0.98)
Environmental Seal	Exceeds IP67 & IP69K	
Salt Fog	MIL-STD-810	

POWER SWITCHING AND CURRENT CARRY RATINGS

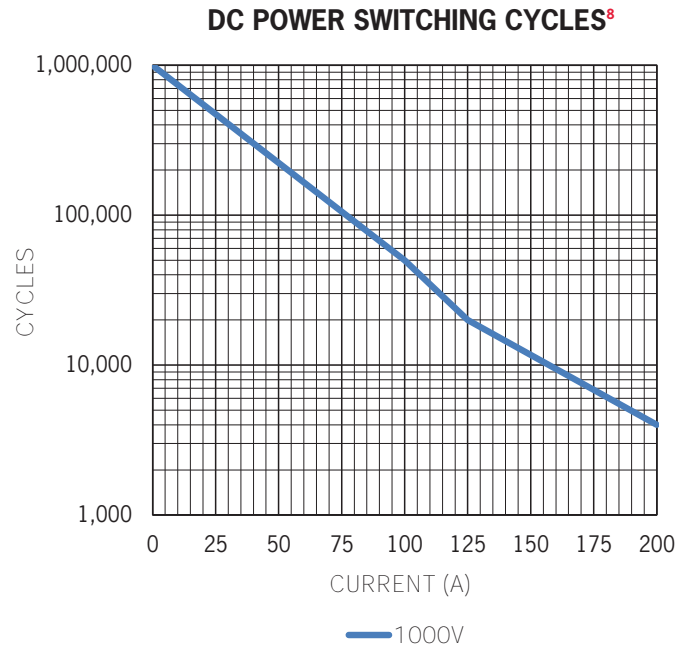

COIL RATINGS at 25°C

Coil P/N Designation	B	C	F
Coil Voltage, Nominal	12 VDC	24 VDC	48 VDC
Coil Voltage, Max	16 V	32 V	60 V
Pick-Up Voltage, Max^{5,7}	8 V	16 V	40 V
Drop-Out Voltage	0.5 to 4 V	2 to 7.5 V	4 to 15 V
Pick-Up Current, Max (75 ms)^{6,7}	4.3 A	1.6 A	0.98 A
Coil Current⁵	0.24 A	0.09 A	0.044 A
Coil Power⁶	2.9 W	2.1 W	2.1 W
Internal Coil Suppression			
Coil Back EMF	55 V	55 V	125 V
Transients, Max (13 ms)	±50 V	±50 V	±75 V
Reverse Polarity	16 V	32 V	64 V

CURRENT CARRY vs TIME with 85°C terminal temperature rise

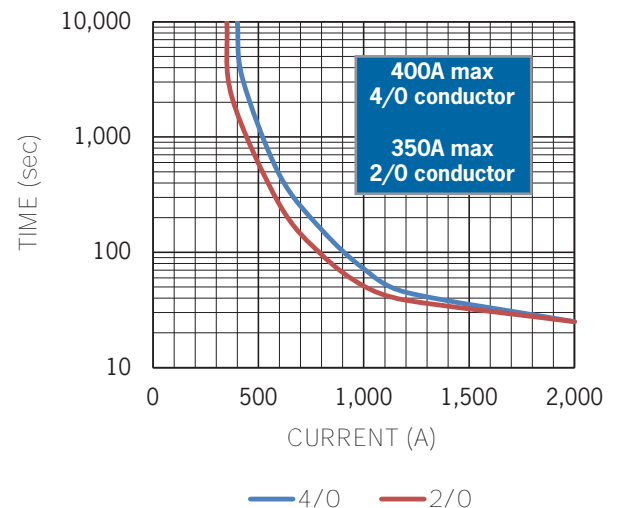



DIMENSIONS

Mounting

M5 Bolts

Case Material

DuPont Zytel FR50
(25% Glass Filled Nylon)

Power Connection

Stainless M8x1.25 Stud
Stainless M8x1.25 Nut
Stainless Lock Washer
Stainless Flat Washer

Torque 10Nm [90in-lb] max

Coil Wire

Silicone, 20 AWG, UL: VW-1

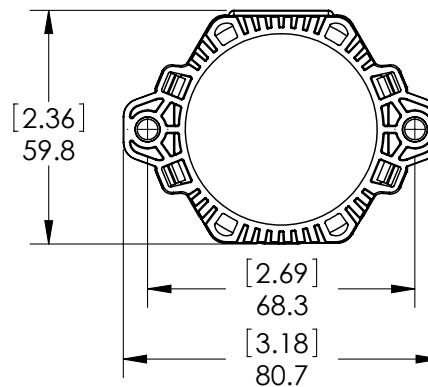
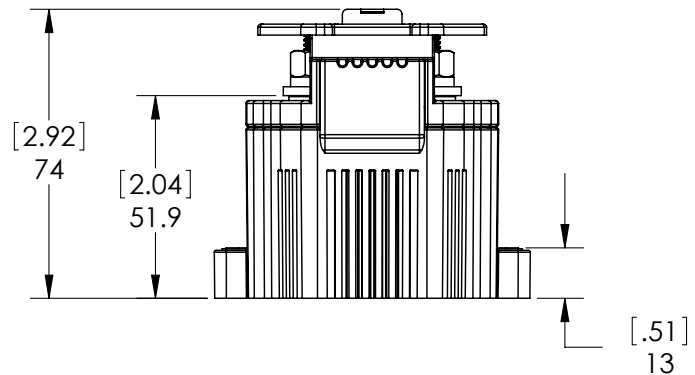
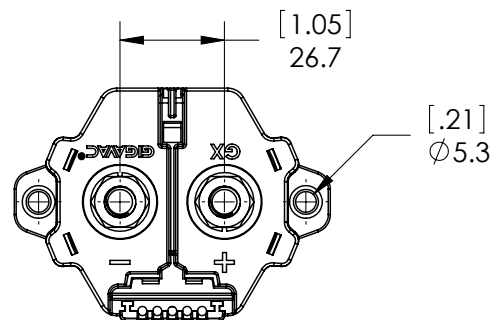

Power Contacts

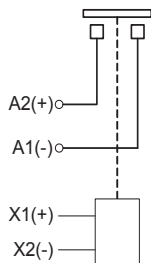

Auxiliary Contacts (optional)

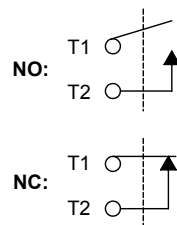

PART NUMBER SYSTEM

HX21	B	A	B
Coil Voltage	B = 12 Vdc, Internal Coil Suppression		
	C = 24 Vdc, Internal Coil Suppression		
	F = 48 Vdc, Internal Coil Suppression		
Coil Termination		A = Flying leads 38 cm (15 in)	
		B = Flying leads 61 cm (24 in)	
		C = Flying leads 122 cm (48 in)	
Auxiliary Contact ⁸			Blank = None
			B = SPST, Normally Open
			C = SPST, Normally Closed

Notes & Definitions:

- 1 Contact resistance measured at currents higher than 100A.
- 2 Operation time is measured at 25°C and includes maximum 7ms bounce.
- 3 Insulation resistance is 50 Mohms after life.
- 4 Contactor can operate up to 125°C in special cases - contact GIGAVAC for details.
- 5 Contactor has two coils. Both are used for pick-up, and then in approximately 75 milliseconds, one coil is electronically removed from the coil drive circuit. The remaining coil supplies low continuous hold power sufficient for the contactor to meet all of its specified performance specifications. This provides low coil power without PWM electronics that can cause EMI emissions and/or cross-talk on control power.
- 6 Contactor is operated by a coil that changes resistance with temperature. Since pick-up current, coil current and coil power are specified at nominal voltage, they will be lower than indicated at temperatures above 25°C and higher than indicated at temperatures below 25°C. Similarly, pick-up and drop-out voltages will be higher than indicated at temperatures above 25°C and lower than indicated at temperatures below 25°C.
- 7 For pick-up testing of contactors with dual coils, the voltage can not be ramped up slowly, but must be applied instantly to at least the maximum pick-up voltage. Otherwise, the contactor will not pick-up.
- 8 Limit make current to 600A to avoid contact welding. Contact GIGAVAC regarding DC Power Switching Cycle Life for part numbers that include auxiliary contacts.
- 9 Auxiliary contact rating is 2A, 24Vdc Resistive load, 100,000 cycles. Minimum current is 0.1mA, 5V. The auxiliary contact is mechanically linked to the main power contacts.

APPLICATION NOTES

- Contactors feature internal transorb for coil suppression. No external diodes should be added across the coil. The use of additional external coil suppression can slow the release time and invalidate the life cycle ratings, or can cause the contactor not to be able to interrupt the maximum current specified. If lower coil back EMF is required, please contact GIGAVAC for assistance.
- Contactors should be installed so that current flows from A2(+) to A1(-). Breaking current in the reverse direction will reduce cycle life estimates, please consult factory for specific application assistance.
- Applications with capacitors will require a pre-charge circuit.
- Electrical life rating is based on resistive load with 27µH maximum inductance in circuit. Because your application may be different, we suggest you test the contactor in your circuit to verify life is as required.
- End of life is defined as when the dielectric, insulation resistance or contact resistance fails the specifications listed.
- Contact GIGAVAC regarding DC Power Switching Cycle Life for part numbers that include auxiliary contacts.